

**1. DE C I I O N**

**3. F**

- **255 H H**

**Π Ε Δ Ο Σ Ι Η Λ Ι Σ Η Ν V**

**2**  
**255 H H**  
**255 H H**  
**255 H H**  
**255 H H**

**255 H H 0 255 H H V**

**2. A L I C A I O N**  
**255 H H 255 H H 255 H H**

- **255 H H**
- **255 H H**
- **255 H H**

**255 H H**

:

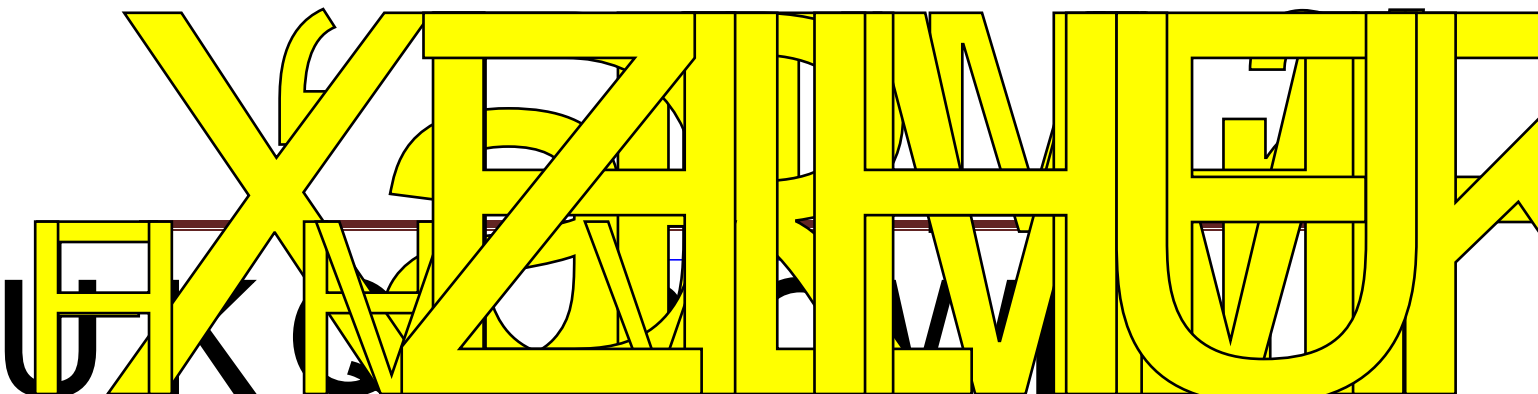

4. IC APPLICATION CIRCUIT

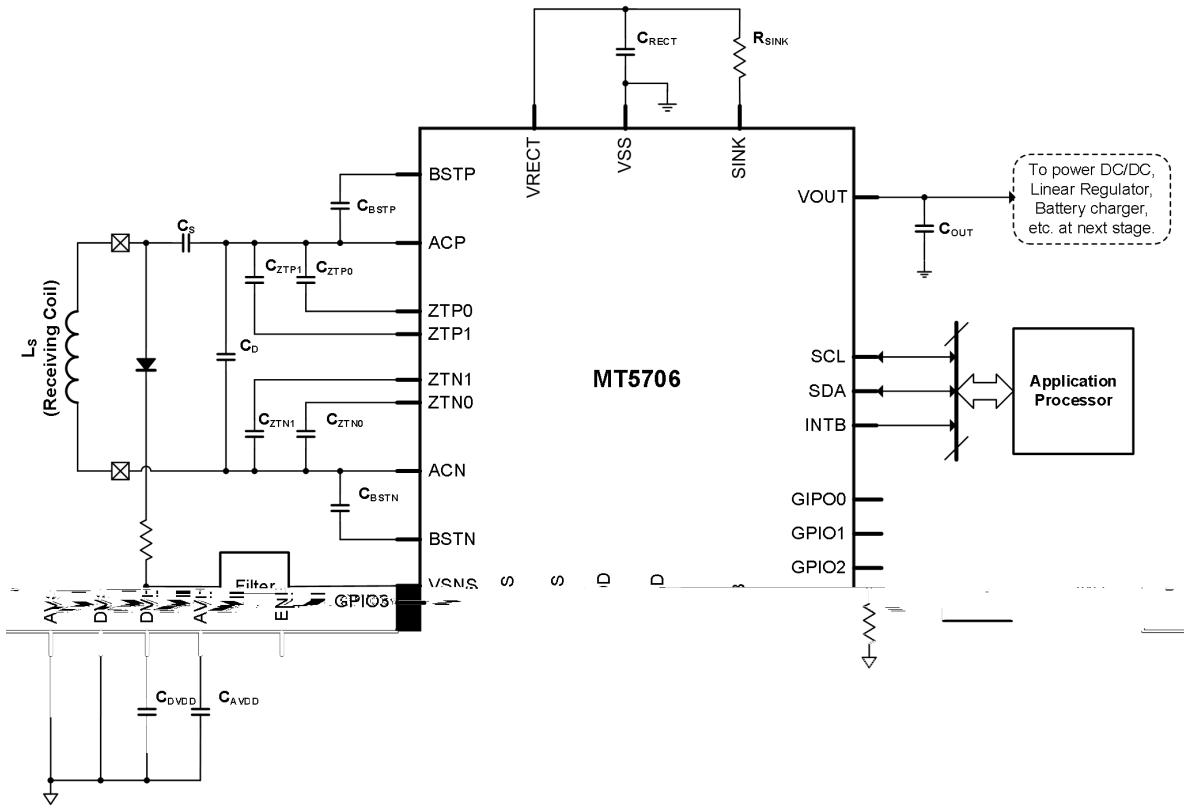

Figure 1 Typical Application Circuit